



THE COMPASS

Official Newsletter of the Great South Bay Amateur Radio Club

January 2015

Volume 43

Issue #1

Upcoming Club Events

Next General Meeting:

Thursday, Jan 29th,
7:30 PM at the EOC

Our First Upcoming Special Events for 2015:
MS Walk @ Belmont State Park

The American Air Power Museum Special Event Station, May 16th and 17th at the Air Power Museum located on New Highway behind Republic Airport in Farmingdale

GSBARC's FREE license classes are on Tuesday evenings from 7:30 to 9:30 PM. The Amateur Extra Classes will be starting on Tuesday, February 3rd

Visit us on Facebook at www.facebook.com/gsbarc



OPSANTA, at JFK, December 10th, I'd say at least 3000 special needs children and at least 1500 of their teachers and aides, FDNY, NYPD, TSA, FBI, Home Land Security and of course Amateur Radio ARES. Of course we had to get Santa's helpers in the picture. - K2IZ

Inside this issue of The Compass...

- Photos from Ham Radio University
- Guess who got an out-of-band notice!
- Evil Mad Scientist Discreet 555 Timer Kit
- Antenna Dilemma
- Shut Down Button for your DHAP
- Chasing Santa
- The Other Side of the Pileup
- KB6NU's Guest Column

Upcoming Special Events

MS Walk @ Belmont State Park
May 3rd

Air Power Museum
May 16th & 17th

Field Day
June 27th & 28th

Maggie Fisher Cross Bay Swim
July 17th

Fire Island Lighthouse
August 15th & 16th

Babylon Village Fair
September 13th

Hope for the Warriors Run
November 7th (Sat)

President's Message

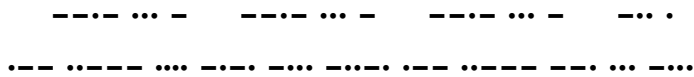

vs. the south!

I don't know if I will be able to attend the general meeting on the 29th. As many of you know I will be having knee surgery at the end of the month so I don't know if I will be up to attending. I can we will see how it goes and hopefully will be able to.

73. John Melfi, W2HCB 

Is My Face RED!

by Bob Myers K2TV

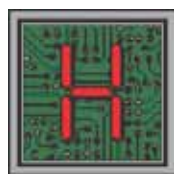

Happy New Year to everyone! 2015 is here and we're off to a great start. Saturday January 4th was the 16 anniversary of Ham Radio University. As always it was an awesome day of seminars, door prizes, seeing old friends and making new ones. As always thanks go out to Tom, KA2D and the rest of the HRU committee for the incredible job they do.

To everyone that helped with setup on Saturday and take-down on Sunday after the event, thank you for all your hard work. Without you the event couldn't have run so smoothly. Thanks also go out to Bob, K2TV, and all the VE's who ran the exam session. Great job guys!

I hope everyone who attended had a good time. By the way, did you catch the News 12 piece? Reporter Jackie Lukas did an awesome job as always with the coverage and it was good to see a young ham being interviewed on News 12. Gabbi, KC2WUP, was interviewed and showed that she's a natural in front of the camera—Great job Gabbi.

We have a lot to do between now and our next event which isn't until May. Ed, KD2ADC, has been working on the beam antennas and rotor for the club. We need to make sure we have all of our antennas in great shape for field day. We are planning a larger than normal field day and we're going to need all hands on deck. To our GSBARC and ladies: we need you on those radios making contacts and getting valuable points for our club! The CW crew are already chomping at the bit and are boasting that they will once again take the honors in our friendly competition between digital and phone. Phone operators, this is your chance to try and win our version of the battle of the north



Recently I was partaking in the fun of the ARRL Centennial QSO party. It sure was fun to have a pileup which is rare if not almost nonexistent for a W2 station. In my exuberance to enjoy the pileup while giving out points, I looked for a nice clear frequency on 20 meter SSB. I saw one of my fellow club members giving out points on 14.345 MHz and I figured I should slide up a few Kilohertz and find a clear frequency. Well without thinking I found a real clear frequency on 14.349 KHz and called CQ. Once someone posted me on the DX packet Cluster, I was off and running.

Not bad until I glanced over to the Dxpocket cluster to see a posting for me with the comment "OUT OF BAND". I quickly signed off and then it hit me! Yes, my center frequency was at 14.349 MHz which is in the 20 meter band, but being on upper side-band my side-band was radiating 2 KHz out of the band. If you are on upper sideband (USB) your sidebands extend out up to 3 KHz from your center (read out) frequency. On lower side-band (LSB) your sideband extends out up to 3 KHz below the frequency shown on your rig's readout.

How could I have made this stupid mistake after being a ham for over 55 years? Well I have to chalk it up to a case of "intermittent dormancy between the headsets." In

Continued on page 5...

Evil Mad Scientist—Three Fives Discreet 555 Timer Kit

By Kevin AB2ZI

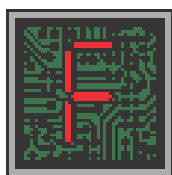

First a little about the 555 timer:

The 555 timer chip made its debut back in the early 70's. It was designed in 1971 by Hans Camenzind while he worked for Signetics, one of the first manufacturers producing integrated circuits back then. Signetics was later bought by The Philips Company. The 555 is a real workhorse in the electronics world and is still manufactured and is in widespread use to this day and is popular due to its versatility and low cost.



A typical 555 IC Chip

The 555 is basically an oscillator chip that has three operating modes:

- Monostable mode: operating as a one-shot pulse generator. You trigger the chip and based on RC time constants external to the chip you get a square wave output for the length of time it takes for the chip to reset itself. Then it waits for another trigger and does it all over again.
- Astable, or free-running mode: Here the 555 can operate as an oscillator switching between states based on the external RC components.
- Bistable mode or Schmitt trigger: Bistable mode operation is what you know as a flip-flop. It is stable in 2 different states and can be triggered to switch whereupon its outputs swap state—a high becomes a low and a low changes to a high then vice versa on the next trigger event.

A typical 555 chip might be internally made up of 2 dozen transistors, 2 diodes and 15 resistors. All of the operating parameters are determined by external resistors and capacitors. There are hundreds of possible configurations that can be made with these chips.

Enough of that... So what's the deal with this kit? What

you get here is a discreet component version of the 555 timer chip, that is, you have a bunch of transistors and resistors on a circuit board that work just like a 555 chip, but instead of only being able to monitor the pins on the outside of the chip, you can actually investigate all the different stages *inside* the chip! Plus it looks really cool with big aluminum legs attached to the board in the shape of IC pins.

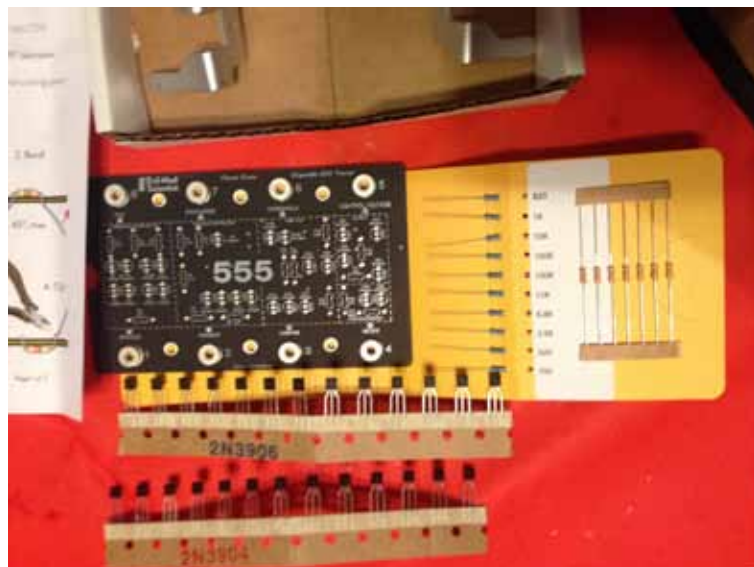

As for the kit itself, it's very well made and thought out. The circuit board has black masking to give it that "chip" look. The silk screening is very well done and shows exactly what components go where, what their values are and what their orientation is on the board in the case of the transistors.

All the components in the kit are well labeled and sorted. All the transistors are on strips (there are 13 3904 NPN and 13 3906 PNP transistors), there are seven 4.7 K resistors and a card with 10 other resistors which are mounted in the order they are installed. Totally idiot proof!

All that's needed to assemble the kit is a 25-50 watt soldering iron, small diameter flux core solder (0.020 to 0.035" dia. recommended), a pair of flush cutters to trim the leads and a #2 Philips head screwdriver for attaching the legs. I also made use of a flux pen just because you can never have too much flux, but you could probably get away with just the flux in the solder if you didn't have any flux lying around.

It took me about an hour and a half or so to do the build. I was taking my time because I tend to make a lot of stupid mistakes when I rush through the assembly of kits. The instructions have you install the resistors first, then the transistors and finally the terminal posts and legs.

The instructions have a small blinker circuit at the end of them for testing your kit to make sure its working. For that you need some extra stuff: two 100K and one 1K resistor, a 1 μ F capacitor (note: needs to be electrolytic), an LED and a 9V battery or similar source for the 9V.

Continued on page 5...

Modify Your Dhap with a Shutdown Button

By Joe Schibani Jr., KD2GAG

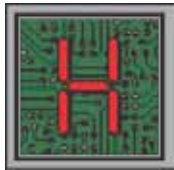

Have you ever wanted to shut down your *Raspberry Pi* gracefully from a physical button? When you power on your *Pi* it immediately powers up, however how do you shut it down without corrupting your SD card? Some hams use their radio to remotely turn it off. But what happens if you're in a rush and forget? Just like a computer, powering it down over time will corrupt the drive, and then you're SOL unless you've imaged the SD card. This article will show you how to add these buttons as seen in the picture here: I've also created a 30 minute detailed YouTube video that can be watched here: <https://www.youtube.com/watch?v=EelIDAH-2jo>



The Parts list:

1. 9.5mm high Tact switch x 2 @ *Radio Shack* (comes in a pack of 4)
2. Subminiature Green LED (2.1v, 20ma) x 1 @ *Radio Shack*
3. 2 pin female jumper wires @ *Amazon.com* x 3

Links for all parts are provided further on in this article.

First we need to program your *Pi* to wait for a button press. You'll need to SSH into it. I like to use Putty.exe, it's free and works well. Log into your *Pi*. Then start your "x11vnc", then VNC into your *Pi*. Once in, run your "file manager" under Accessories. Then create a "scripts" folder. Open the scripts folder, then right click inside that folder and create a new "blank file" and name it "shutdown.py". Then open up that file in "leafpad", then add this code in that file:

```
---- start code --- < do not add this
# DHAP/RPi shutdown Routine
import RPi.GPIO as GPIO
import time
import os
GPIO.setmode(GPIO.BCM)
GPIO.setup(25, GPIO.IN, pull_up_down = GPIO.PUD_UP)
def Shutdown(channel):
    os.system("sudo shutdown -h now")
GPIO.add_event_detect(25, GPIO.FALLING,
callback = Shutdown, bouncetime = 2000)
while 1:
    time.sleep(1)
---- end code ---- < do not add this
```

You can program any GPIO pin you like, I used GPIO25 (Pin 22). If you wanted to change it, find 25 and change to the GPIO pin you want. Save the file. Now we need to have the *Pi* run this file on startup.

Open up "LXterminal" also under "Accessories" Enter in this command:

```
sudo nano /etc/rc.local
```

We are going to edit this file (rc.local). It may not exist, once in it, enter in this line:

```
sudo python /home/pi/scripts/shutdown.py
```

Then save it. We are now done with the programming of the *Pi*. On to the buttons...



The soft reset button. You'll need to solder jumper pins to this area show above. This is where our reset button will get connected to. Radio shack did not sell them individually, so I had to remove one off of a dead PC mother board. The switches used are Radio shack model # 275-003. Link Below.

<http://www.radioshack.com/12vdc-50ma-spst-6-2x6-2-mm-smt-tact-switch-9-5mm-high/2750003.html#.VlclNnsu2fk>

They are very tiny. I wanted it to be neat and discrete. I did not want to accidentally turn off or reset the DHAP while in use. They are SMT tact switches. Soldering wires onto it will be tough.

Use these jumper wires from amazon:

http://www.amazon.com/Female-2pin-Female-Jumper-Shield-experiment/dp/B00AMBHSES/ref=sr_1_3?ie=UTF8&qid=1418143731&sr=8-3&keywords=2pin+jumper+female

I drilled two holes where I wanted my buttons to be. You can put them anywhere you like. I put them on the bottom so they would not be accidentally pressed.

You'll need to solder the jumpers onto the switches. Give it some length so if you wanted to re-open it, nothing will break when you do.

You will be hot gluing them into those holes you drilled earlier.

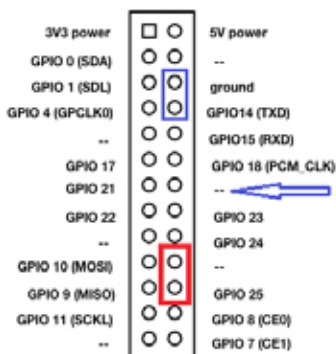

Raspberry Pi A/B		Rev 2 P1 GPIO Header		
Pin No.	Color	Pin No.	Color	
1	3.3V	1	2	5V
2	3.3V	3	4	5V
3	GPIO2	5	6	GND
4	GPIO3	7	8	GPIO14
5	GPIO4	9	10	GPIO15
6	GND	11	12	GPIO18
7	GPIO17	13	14	GND
8	GPIO27	15	16	GPIO23
9	GPIO22	17	18	GPIO24
10	3.3V	19	20	GND
11	GPIO10	21	22	GPIO25
12	GPIO9	23	24	GPIO8
13	GPIO21	25	26	GPIO7
14	GPIO11			
15	GND			

Red is for the power down button. The blue is for the optional LED power light. The arrow indicates another ground connection. GPIO14 works perfectly as our power light, as it goes on and off when powered on, then off. There is nothing to program. I'm using Pin 8 and 14, however you can use pin 6 & 8 for your LED light.

Pick one of the jumpers/switch assemblies and plug it onto the reset jumper you soldered on earlier.

Then connect the other jumper to pins 20 & 22.



You are done! Power on your DHAP and see if it works. Please check out my video for more information as it is much more detailed. 📺

Is My Face RED! cont'd from page 2...

the heat of battle in a contest, chasing a DX station or just looking for a nice quiet frequency, it is easy to forget and your rig readout will not necessarily tell you.



Image from the "OO" showing the exact spectrum of Bob's signal. The red line is the top of 20 meters!

Of course I got a nice email and an *Official Observer Advisory Notice* from W8RXX. Thankfully we have these hams volunteering as Official Observers. They are there to let us know when we are breaking the FCC rules and regulations or have a poor quality signal. If you get an OO notice you do not have to reply to it, but it is not a bad idea to send a thank you to the ham that sends you the report.

So the moral of this story is think before you go ahead and jump on a frequency. Am I too close to the band edge or the edge of the area where my license allows me to operate? Just because a station is operating on a specific frequency or mode doesn't mean that they are operating properly. Everyone makes mistakes, but *IS MY FACE RED?* You bet! 📺

555 Timer Kit cont'd from page 2...

I put the parts together on a breadboard with the kit sitting on top of it and it worked perfectly.

I know there are a lot of you out there that don't do a lot of soldering and/or kit building. For the most part I usually recommend kits like the Hendrick's QRP dummy load (www.qrpkits.com) for beginners to get experience soldering. I also tell people not to be afraid to take on a little more than they think they can handle if they have someone who can guide them when they encounter difficult steps because you learn a lot that way. But I have to say that this kit is a real winner for beginners. All the components are through hole and large enough that you don't need to invest in an electron microscope to work on them. Plus you get an educational tool when you are done. The site includes links to a free PDF book with 50 circuits and the internet has more resources than there is junk in the back of N2OEP's car! The website is: <http://shop.evilmadscientist.com/> 📺

How do we promote better operating practices?

By Dan Romanchik, KB6NU

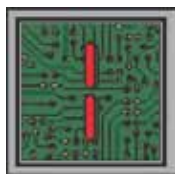

A lament that I often hear is that many amateur radio operators either don't seem to understand the importance of good operating practices or just don't care about them. Just this morning, a reader sent me an e-mail saying, "I think there are too many hams out there that don't how to call a station on split frequency. It's amazing that we have so many dummies out there."

I wrote back, saying, "Maybe we need another type of Official Observer, called the Operating Observer. This group would note when operators aren't following good operating procedures and send people gentle reminders." Of course, as soon as I hit Send, I knew this wasn't a very good idea. As my reader noted, this would be a thankless job, and chances are the poor operators would simply ignore the notices, anyway.

Even so, there must be some way to encourage good operating procedures. One effort to promote better operating procedures is the DX Code of Conduct (<http://www.dx-code.org/>). This is a list of 13 suggestions to make DX operation, particularly pileups, less chaotic. The website includes a small image that you're supposed to post to your website to show that you support the Code. While this is certainly a step in the right direction, I wish there was something that we could do to be more proactive in improving operating practices.

There is, of course, the ARRL Operating Manual. This publication is now in its tenth edition and is a valuable source of information about how to operate properly. The problem is only a fraction of the amateur radio operators on the air have a copy, much less read it.

Another attempt at promoting good operating practice is the ARRL's A-1 Operator's Club ([http://www.arrl.org/a-](http://www.arrl.org/a-1-op)

1-op). While a noble effort, I think that this program really requires more promotion. In addition to being more aggressive about finding A-1 operators and bringing them into this "club," the ARRL should use it to promote better operation. Perhaps a series of videos with the A-1 Ops logo showing how to operate split or how to properly call CQ would help improve operating practices overall.

Talking about videos, I'd be surprised if there weren't already some YouTube videos that illustrate good operating practices. If you know of any, please e-mail me. It would be great to have a list of really good ones that I can send to people who want information on how to operate better.

What do you think? Do we need to be more proactive about encouraging hams to use good operating practices? If so, how do we go about it? What do you do to encourage better operating practices? 

When he's not writing about amateur radio, Dan, KB6NU enjoys Elmering new hams and working CW on the HF bands. For more information about his operating activities and his "No-Nonsense" series of amateur radio license study guides, go to KB6NU.Com or e-mail cwgeek@kb6nu.com.

In Memoriam

On December 24th, 2014 Amateur Radio lost one of our biggest supporters when New York State Senator Owen H. Johnson passed away at the age of 85.



In Loving Memory of
NEW YORK STATE SENATOR



OWEN H. JOHNSON
July 3, 1929 – December 24, 2014

*"Just do what you feel is right
and you can't go wrong."*

Owen H. Johnson

CLAUDE R. BOYD-SPENCER
Funeral Homes
448 West Main St., Babylon, NY
(631) 669-2400



The Antenna Dilemma

By Phil Jacobs KD2GFO

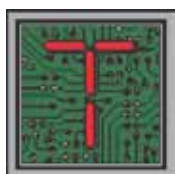

The problem: How get a G5RV Jr. in the air with only one tree 60' tall on a 100'x100' plot with the house set dead center on the property.

After much thinking, sketching, and talking with various club members (KC2SYF, KC2ZQO and others) the idea was arrived at to use a hinged mast at the southern end of the property. So what to use as a mast and what to make it out of? Among the requirements:

1. Has to be a least capable of getting the wire up 30 feet.
2. Has to be rigid enough to withstand being walked up (lifted) into place without failing.
3. Has to be fairly stealthy—too many antenna CCR's in the town I live in.
4. Cheap to make yet durable.

The material chosen for the mast was 12 foot fir 2 x 4 lumber. Six pieces were offset laminated with Gorilla Glue© and 3-1/2" #9 deck screws so that all butt joint seams were supported on the opposite side by an intact length of 2 x4, creating a 4 x 4 piece of lumber 36 feet long which was cut to 30 feet after the glue had cured. Gorilla Glue was chosen because it is a phenolic cement that is 100% water proof when cured.

The next problem was what to use as a base? Requirements here were:

1. Has to strong enough to take the load while the mast is being walked up into place.
2. Weather proof.
3. Withstand being set in concrete and buried without rotting.
4. Fairly inexpensive.

Pressure treated 4 x 4 lumber was chosen. Two eight foot sections were bolted together using a spacer made from a section of the trimmed mast.

Two 18 inch pieces of 5/8" threaded rod with appropriate washers and nuts were used to join the spacer and 4 x 4's at 12" and 36" from the top of the base assembly.

A post hole digger was used to dig a placement hole 3 feet deep; the base assembly was placed in the hole and braced vertical using a level and side braces. The hole was back filled using 50lbs. of concrete mix and earth. This was allowed to set and the assembly un-bolted. The spacer was used to transfer the through holes to the mast by clamping and drilling.

The next job was to attach the mast to the base and walk it up. Attaching the mast was straight forward simply bolt the lower end of the mast to the base at the 3 foot hole and walk it up, but wait, not so fast! KC2SYF and I tried three times, once even using a ten foot step ladder. The best we could do was get the mast to a 30 degree angle before physics took over and stopped us dead in our tracks. You see the mast was acting like a lever with a movable fulcrum, thus the closer we got to the hinge point the longer the lever (the mast) became relative to the fulcrum and the amount of force needed to lift it grew exponentially to the point where we could not move it past 30 degrees. Now what?

The rest of the week passed by and I stopped in at the Saturday open house and bounced the problem off several of the members present. KC2ZQO asked me why I couldn't use a winch like they do on the fold down towers. He brought over one of the numerous catalogs opened it to the tower section and the light bulb went on: I could use a derrick pole to winch the mast up! Again it had to meet the same criterion as the materials for the base. I already had an old boat trailer winch all I needed was some kind of pulley, an eye bolt, cement, and mast material. Digging around the shop I found a 4 in. wash line pulley which was promptly removed from its hanger and a 5 in. stainless steel 1/4-20 bolt with the appropriate hardware. A 12 ft. pressure treated 4 x 4 was obtained. A pocket hole was bored into the 4 x 4 near the top with a chainsaw and the pulley mounted in the pocket after the winch cable had been threaded through. The winch was mounted on the 4 x 4 at 4 feet above ground level and the 4 x 4 was secured in a 40 in. deep hole set at 10 degrees to the vertical away from the base to provide crank clearance. This hole was back filled with concrete and earth and allowed to set. The derrick pole was braced to the base with two 12 in. pieces of 2 x 4; one on each side of the derrick pole. The math was

Continued on page 9...

The Other Side of the Pile

by John Smale, K2IZ

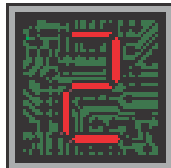

014 was the 100th year celebration of the ARRL's existence and as part of the celebration they have been running a couple of on the air events, One is to try and work all 50 states using the ARRL's W1AW/ portable call sign, the other is to work ARRL members on different bands and modes. All ARRL members were worth a certain amount of points. In my case, as past Section Manager for NLI, K2IZ was worth 100 points per contact.

In my 40 years of being an amateur I have operated many contests and 99% of the time I operated the "search and pounce" mode rather than the "run" type of operation. This was mostly because I run low power, but during the ARRL Centennial other stations were looking for the high point stations. I started calling CQ, as did my neighbor Bob, K2TV. Except when we operated as W1AW/2, it was the first time we had operated on the other side of the pile ups. Bob commented "where else can a K2 cause a pile up on the air!" We both listened to the various operating tips passed around by other operators over the years, but this was the first time we got firsthand experience as to what DX operators go through when they work pile ups.

The new N1MM Plus contest logging software was used in the DX'expedition mode. The programmers made some really great updates to its system in the new "Plus" version. Most of us use it for contests and we've learned to make the tweaks and additions to make it work the way we want. Configuring the F keys for CW operation really makes for easier operating, but it's still nice to be able to use the keyer for quick personal greetings.

The first thing I did was to check to see what bands were active, find a clean spot, listen, and then send out "QRZ de K2IZ", basically asking is the frequency in use. If there was no answer I'd quickly spot my call sign on the VE7CC DX cluster and then start calling CQ. That is when the fun begins, one minute nobody is on the frequency, the next it sounds like the entire world is calling.

Now is the fun part. Picking out individual call signs out of this mass of sound, then you start hearing what you've been taught over the years, the slightly off frequency stations, different pitch on CW, the tail enders, on phone a female voice comes through better than a male voice. You also find out that there are a few changes you need to make to your station for this type of operation. On voice a foot switch is mandatory. I am using a Heil Pro Traveler headset. It has a push button built into the cord, terrible to use in a contest. I end up with one hand on the push to talk and having to one finger type on the computer with the other hand, after an hours operation my thumb was sore and my hand cramping up.

I did a run on 15 meter phone one time, over an hour operating a pile up, after the first few minutes I heard one station comment "you'd better start doing by call areas". I had heard this done many times before and it was very good advice, because of the band conditions I started with the 4th call area, this meant only stations with the number 4 in their call signs. After I whittled down the 4's I switched to the 5th call area, all the way to zero and then starting at 1.

You'd be amazed at the number of stations, mostly the same ones, that cannot understand simple instructions, I'd be asking for 5's and a 2 would try to work me. I would be asking specifically for any stations with a 5 in their call and this guy would continue calling me with a 2 in his call. Times like this I appreciated the stations that are referred to as the "frequency police" telling the station "he's working 5's only".

I've had a lot of fun doing the centennial part of the contest, I've found out my antenna system (new beam, new coax) that I just replaced really works nicely. For those of you that know my wire antenna set up, you know it doesn't run in a straight line, it's an off center fed dipole, but in the late afternoon I was able to work Sweden, Venezuela and Japan on the 17 meter band on CW, not loud, had to dig them out of the noise but they are in the log.

If anyone is interested we will be more than happy to pass along our experiences from this operation, there are still a few more opportunities coming up, in Sweepstakes our section, NLI, is considered a fairly rare contact as there are not that many contest operators left in the section. So we become a sought after station late in the contest when stations are trying for a clean sweep. 📍

Chasing Santa

by Caryn Eve Murray, KD2GUT

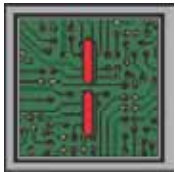

actually believed in Santa. Call me crazy but I spent the last week or so of December chasing that red-suited rock star across the bands, lusting for his QSL card in my stocking, in an on-the-air special event organized by Radio Arcala in Finland. But Santa - as OF9X and OH9SCL – was making fast tracks. I chased him across Finland, westward toward the Baltic Sea. But as soon as I would spot him on one of the HF phone bands, there was nothing left but a telltale pileup of reindeer poop. He'd already dashed away home to some magical CW realm, or vanished into some other mode.

No Virginia, there was no Santa Claus. (I swear I hadn't been naughty in 2014. Just ask the FCC.)

My luck was just as bad trying to tune in a bunch of research scientists doing on-air caroling Christmas Eve at the remote McMurdo Station in Antarctica. I'm told I wasn't the only frustrated music fan unable to copy them but since working Santa was already a bust, I figured the carolers were disrespecting me too.

Things were looking pretty ho-ho-hopeless. Holiday special events in ham radio were quickly becoming humbug.

Ultimately, it wasn't the North Pole, or even the South Pole, that delivered Christmas joy. It was Kansas City, Missouri. There, local hams were marking the centennial of World War I's Christmas truce with a two-day special event marathon broadcast on Dec. 27 and 28. The voice of *WWIUSA*, the amateur radio voice of that city's *National World War I Museum*, came 5 and 9 through my rig. It was a brief QSO to remember, with an operator named George, and a chance to be part of the DX scene with someone at the museum's Liberty Memorial.

No, I never did get that piece of Santa, and Antarctic antics left me out in the cold, but on Dec. 28, I made peace with my holiday frustrations as my rig helped me touch history from a still-young 20th century, a time when radio was still an emerging technology.

Of course, I sent a QSL card – then marked it in my yule log. ☺

Antenna Dilemma...Continued from page 7

done to ensure that the eye bolt when placed through the mast would be directly opposite the pulley when the mast was raised. This prevented the mast from being placed in compression during lifting. The antenna line pulley with line was placed at the top of the mast and secured. Now the moment of truth was at hand.

“Use the Force”

Well it couldn't be put off any longer, it was now or never. The winch handle was attached, the ratchet set, and I began to turn the handle. Mike, KC2SYF, and I couldn't believe our eyes, up and up and only one finger was needed to turn the winch handle as it went up all the way with no problems and no real work!

The mast is guyed at the three 120 degree points with three guys set at 75% mast height and again at 75% of the remaining height with three more guys for a total six. The guy material is 3/16" diameter UV resistant Spectra© line with a breaking strength of 1600 lbs. for each line so each guy sector has a combined breaking strength of 3200 lbs. The total system has a breaking strength of 9600 lbs. so I don't think it will go anywhere. A sling shot with a tennis ball and fishing line was used to shoot the antenna line up into the big tree. The antenna line was pulled up and tied off, then the line was pulled up the mast and tied off to a cleat. The feed line was attached and the antenna is up and I'm on the air! ☺



**(Left) The mast raised and guyed.
(Right) The antenna and feedline.**

Ham Radio University 2015



(l-r cw) Kerri, Donna, Patty, Adele, Jackie & Gabbi



James, KD2GPF renews his GSBARC membership with Kevin, AB2ZI



Art, WA2KXE, GSB's Secretary, mans the club table.



George, N2GA with Pete, W2JV at the AMSAT table.



Pete, W2JV's AMSAT forum live streaming...



Pete, W2JV with GSB's new Treasurer, Bob, W2YW

YAHOO!

GSBARC has a New Yahoo Group and the old one has been deleted

If you are a member in good standing and want to join the club's new Yahoo group, go to:

<http://groups.yahoo.com/neo/groups/gsb-arc/>

and click on "Join Group" Be sure to add a note when filling out your information with your call sign so we know who you are!

Club Apparel

Want a shirt, jacket, hat, sweatshirt or t-shirt with a Great South Bay club logo? We now use *Mr. Shirt*, located at 80 East Montauk Hwy in Lindenhurst (www.mrshirt.com). Now you can get color matched backgrounds on your logo too. Check them out...

ARES/RACES Information

Div. 1—Town of Babylon ARES/RACES

Net: 146.685/R, Mondays 8:15 PM
EC/RO: John Melfi, W2HCB, (631) 669-6321

Div. 2—Town of Huntington ARES/RACES

Net: 147.210 MHz +600/ PL 136.5,
Mondays 7:00 PM

EC/RO Steven W. Hines, N2PQJ, (###) ###-####

Div. 3—Town of Islip ARES/RACES

EC/RO: John J Blowsky, KB2SCS, 631-467-2410

Div. 4—Town of Smithtown ARES/RACES

Net: 145.430 MHz, PL136.5, Mondays 7:30 PM
EC/RO: Joe Albertus, KB2JOE, 631-664-6709

Div. 5—Town of Brookhaven ARES/RACES

EC/RO: Joe Werner, KC2BPS, 631-730-8694

Div. 6—Riverhead ARES/RACES

EC/RO: Donald Rollock, W2EUL, 631-929-0705

Div. 7—Southampton ARES/RACES

EC/RO: Dennis O'Rourke, KB2ZWW, 631-728-5424

Div. 8—Southold ARES/RACES

EC: Don Fisher, N2QHV, 631-765-2757
RO: Charles Burnham, K2GLP, 516-779-4983

Div. 9—East Hampton ARES/RACES

EC/RO: Nat Raynor, N2NEI, 631-324-3738

Div. 10—Shelter Island ARES/RACES

EC/RO: Neal Raymond, N2QZA, 631-749-9330

Suffolk County

ARES/RACES Net:

Mondays 2100 Local - 145.330/R (136.5 PL)
Alternate Frequency - 145.370 (136.5 PL)

New York State

RACES Net (HF)

Sundays 0900 Local, 3993.5 KHz LSB

2015 VE Session Dates

- January 24th
- February 28th
- March 28th
- April 25th
- May 23rd
- June 20th (3rd Sat. due to Field Day following weekend)

All sessions are at the Town of Babylon EOC, located in the basement in the rear of town hall. Please bring photo ID, a copy and your original amateur radio license (if you have one), and any CSCE's you may have. Non programmable calculators are allowed. The exam fee is \$15 payable by cash or a check made out to "ARRL VEC".



All Flag & Flagpoles

FLAGS • BANNERS • FLAGPOLES & REPAIRS

SPECIALIZING IN CUSTOM FLAGS AND BANNERS

97 Gnarled Hollow Road, East Setauket, NY 11733

Tel: 631-751-5500 Outside NY: 800-247-8331

Fax: 631-751-5505

Website: www.all-flags.com • E-Mail: info@all-flags.com



24 Hour
TOWING SERVICE

Hassell

Auto Body

390 ROUTE 109 WEST BABYLON, NY 11704

www.hassellautobody.com

(631) 587-5500 1-800-HASELL FAX: (631) 587-7845

Need Antenna Work?

Sign-up on the list at the EOC. Please supply as much information about your situation so the committee can be properly prepared with assistance and tools when they come to your QTH.

Club Name Badges

Club name badges are available from *The Sign Man* (www.thesignman.com) of Baton Rouge, LA.

The badges which are 1-3/4 in. x 3 in. If you visit The Sign Man's webpage you can order the badges by using a drop down selection on the orders page and clicking on "Great South Bay ARC - NY"



January Birthdays

Rich, AC2HX

Joe, W2FED

Ray, N2ZEM

Rich, K2BBQ

Dave, AK1NS



Pride Equipment

Corporation

150 Nassau Avenue,

Islip, NY 11751

(800)-564-7743

Fax: 631-224-5152